



HONDA 120 TECH MANUAL

USAC NATIONAL TECH COMMITTEE

DIRECTOR JOHN IMPELLIZERI

USAC NATIONAL SERIES DIRECTOR

JERRY COONS

Feb 1, 2018

2017 UNITED STATES AUTO CLUB



HONDA 120 – Tech Manual
Updated Feb 1, 2018
FROM 2015 USAC NATIONAL .25 MIDGET RULE BOOK, APPENDIX I
731 Engine Protest Rules (applies to Honda and Briggs classes only)

1. Protest shall be from within the same division of class only, i.e. Jr., Sr., Lt.& Hvy. 120-160, Animal or World Formula only. Competitors in the same division, and in the same race may make a protest on an engine. No protesting in Rookie Class. Handlers may not protest more than one car per event and may not protest same driver more than once per calendar year.
2. Honda Engines and World Formula/Animal Engines may be protested for \$400.00 cash only plus any applicable shipping charges if necessary. No protested related inspection will be started prior to the funds being posted with the proper official.
3. This protest form and cash must be submitted to the Chief Steward, or his/her designee, before the end of the race that the protested engine is participating in I.E. Checkered flag lap complete.
4. The protest can only be made during an A-Main event.
5. The person protesting the motor must have their engine inspected for compliance first. If the “protester’s” engine is found illegal the protest is null and void and the protest fee will go to the club. If the “protester’s” engine is found legal the protest will continue.
6. The Chief Steward, his/her designee, will hold the protest money until the protested engine has been inspected for legality. The protested engine shall be tagged/marked and sealed as soon as it car comes across the scale if it has not been sealed prior.
7. The protested engine as well as the engine of the protested party shall be immediately taken to impound and/or presented to the Tech Director for inspection. Engine must remain in impound and in the possession of tech officials throughout the entire process, including shipping to USAC Headquarters or designated tech inspection station and the transferring of funds.
8. Both protester and protestee have the option to be present at the time of inspection.

9. Any protest that is withdrawn will be assessed a \$50.00 fee that will be paid to the host club.
10. If the protested engine is found to be illegal, the motor must be completely torn down to check for additional illegalities. The Tech Director must confiscate all illegal parts and related parts from the protested engine and shall immediately forward them to the USAC Headquarters. If engine is found illegal protest money minus \$50 plus any shipping cost will be returned to the person filing the protest.
11. Refusal of protest, destroying or withholding of parts or any other lack of cooperation in this protest or inspection process shall be interpreted as an admission that the engine is illegal and shall subject the driver and handler to the conditions set forth in the Suspensions Program.
12. Any teched or protested engine, block or part which are deemed to be over maximum wear limits in one or more spots but is under maximum wear limits in other spots is subject to confiscation but not DQ'able.
13. Note: Reference to Confiscation due to Wear Limits in "Engine Block Internal Rules" of both Manuals.
14. If the engine is found legal \$400 will be given to the person whose engine was protested.

732 Engine Suspension Rules

Handlers and drivers guilty of having an engine declared illegal at technical inspections shall be disciplined as follows:

1. First offense – up to 30-days and/or 4 race suspension for handler and driver from participating in the respective class at any USAC Sanctioned event.
2. Second offense within one year of first infraction – up to One-year suspension for handler and driver from participating in the respective class at any USAC Sanctioned event.
3. Third offense within two years of last infraction – Suspended for life from USAC's .25 Midget division.
4. Suspension for life is open to review by USAC.
5. Suspension shall begin immediately.
6. Illegal **Honda, Animal and World Formula** part/s shall be sent within five Business days to the USAC office or designee for review. The Tech director has 48 hours to determine if the part/s are legal or illegal. If the part/s are determined to be legal it shall be returned to handler. Handler shall be notified if part/s are legal or illegal. All illegal or confiscated part/s shall be sent to National Tech Director. All legal parts shall be returned to handler.

7. If a **Honda** motor is found to have a valve oil seal during tech it shall be a race disqualification only.
8. Spark plugs, exhaust & **ignition timing** infractions are a race disqualification only.
9. Failure to go to tech and/or impound will result in a race day DQ. Refusal of tech shall be interpreted as an admission that the engine is illegal and a suspension from the class shall be immediate with all awards and qualifications being revoked with a six- month suspension driver and handler suspension at any USAC Sanctioned event.
10. For the purpose of this rule only, if a handler has multiple cars competing at one race event and more than one engine is found to be illegal at that event; it will be considered to be one offense.
11. All membership suspensions must be sent to the National Tech Director within 5 Business Days.
12. Illegal Rookie engine parts shall be confiscated (Honda or Animal) but the suspension shall not be levied against handlers or drivers for the first offense. The second offense shall result in a 30 days Suspension from Rookie.
13. The cost to appeal a suspension is \$175 plus any associated fees. The appeal must be made within 3 days of the ruling.

UNLESS IT SAYS YOU CAN DO IT YOU CANNOT DO IT!!!

GENERAL RULES

1. **GX 120 UT2 ENGINES WILL BE ALLOWED FOR USAC COMPETITION.**
2. Only stock Honda GX120 HX 2 Engine and gearbox will be used in this class. All parts will be stock Honda specifically made for the Honda GX120 K1HX2, U.S.GC01 GCAHK, and Canada GCAAT. Honda OEM 120 replacement blocks may be used. Must be an OEM Honda replacement block. No aftermarket blocks or components.
3. All stock Honda parts must be used and properly installed with the following exceptions:
 - a. Governor system may be partially or fully removed with the exception of the steel drive gear on the crankshaft. This gear must remain intact. If shaft is removed hole must be plugged. Hole can be tapped for thread or epoxy. No welding.
 - b. Factory air cleaner must be removed. Any air filter may be attached to the outside of air filter adapter. Outer wear style or equivalent can be used over carburetor only with no adapter. The approved air filter adapter may be run with or without an air filter. Any air filter may be used with adapter as long as there are no devices inside the air filter or adapter. (I.E. Springs not allowed) Hose from valve cover must go into a catch can. (We are using "outerwear" to define a style not brand name).

4. The use of air filters during qualifying at asphalt and dirt events is illegal. The Senior Tech. Official reserves the right to allow filters at any event that it's deemed necessary.
5. Any type of throttle linkage may be utilized. Carburetor shall remain unaltered with the exception of the black plastic piece on the upper end of the throttle shaft. This is the ONLY part of the carburetor that may be altered, removed or material from the black plastic piece is allowed. No additional material may be added to the carburetor. i.e. bolt in black plastic piece or tubing on throttle stop.
6. Stock Honda fuel tank must be removed.
7. Recoil starter must be removed. Pull cup may be cut down for washer. Must use original cup.
8. Exhaust:
 - a. Stock Honda muffler will be removed. Mounting flange may be cut off of muffler and used as adapter flange. Any transition from the "D" shape of the exhaust port to round must take place within the thickness (0.250" max). of the flange. This applies to all exhaust systems. No steps or tapers allowed, grid marks are allowed past .25" flange area. No suspension for exhaust flange or pipe infraction just disqualification. If an after market flange is used, maximum allowable flange thickness will be 0.250". If slip on type flange assembly is used, pipe stub will be a maximum 0.880 " outside diameter tubing with a maximum overall length of 1.500". Pipe stub must be inserted into exhaust pipe at least 0.750" and will have minimal exhaust leakage.
 - b. All USAC .25 midget mufflers to be used will be 4 to 8 hp Briggs & Stratton, part number 294599 or equal equivalent. Muffler will be internally unaltered except that the round cup shaped baffle may be welded to the perforated baffle without moving it's original location. No drilling holes in the baffles. Inside seam of baffle must be straight edged. (NOTE: Some seams may not be straight). Threads will not be removed from the muffler. It is ok to weld a washer or nut on the flange for a place to apply safety wire and/or spring. **Muffler cannot be more than 1/2 turn from being hand tight.**
 - c. Exhaust pipe will be a maximum of 1.000" outside diameter with a length of 20.0" to 26.0" including a threaded pipe coupler welded to the end of the pipe in order to screw muffler in place so that muffler may be removed for inspection. Pipe coupler will be a standard, unaltered, 3/4" NP, threaded coupler. Length will be 1.000" minimum to 2.250" maximum. Exhaust pipe length will be measured by using a small diameter hose inserted through pipe to measure overall length. Flange and coupler will be included in the overall length when measuring pipe. No coating of any type may be applied to the interior of any part of the exhaust system. The intent of this rule is to have all of the exhaust pass through the muffler. All measurements are to be taken with the component pieces in the same position as they were installed and on the car.
 - d. Steel or Stainless are the only materials allowed for exhaust pipes.

9. Choke butterfly and shaft must be removed. Only the top hole may be filled only with silicone or old shaft cut down. No addition or subtraction of material in the bore or venturi of the carburetor.
10. Oil level switch may be disconnected but switch assembly must remain intact in crankcase.
11. Gearbox may be rotated to any desired position.
12. On-Off ignition switch may be removed, and hole covered. (any material: no welding)
13. All pin measuring gauges are plus tolerance. Use Class ZZ pin +0.0002
14. Exhaust oxygen sensor or temperature sensor attached to any part of Honda exhaust system is illegal.
15. Valve seals are illegal.
16. Cryogenics of any Honda part is illegal.
17. Taking parts out of service - Reference: Wear limits in Engine Block Internal section.
18. DQ only – Not suspension for: Exhaust, Air Filter Adapter, Spark Plug, Ignition Timing
19. Shroud may be factory RED or BLACK.
20. Honda gaskets for the intake, carb, side cover that are green on one side and tan on the other in color are legal, as well as blue in color on both sides.
21. All seals must have the stock spring installed in the seal and in its proper location.

TECH PROCEDURE

Modifications or machining of any parts except the gasket surfaces between the cylinder head and block, and main jet in order to bring them to stated minimum or maximum specs (blueprinting) is not legal.

1. External visual check of engine for required components: Pipe and muffler, shrouds and sheet metal, and oil level sensor (this can be partially observed from outside).
2. Factory air cleaner must be removed. Any air filter may be attached to the outside of air filter adapter. Outerwear style or equivalent can be used over carburetor only with no adapter. The approved air filter adapter may be run with or without an air filter. Any air filter may be used with adapter as long as there are no device(s) used inside the air filter or adapter. (I.E. Springs not allowed) hose from valve cover must go into a catch can. (We are using "outerwear" to define a style not brand name).
3. The use of air filters during qualifying at asphalt and dirt events is illegal. The Senior Tech. Official reserves the right to allow filters at any event that it's deemed necessary.
4. Any Type throttle linkage may be utilized. Carburetor will be unaltered with the exception of the black plastic piece on upper end of throttle shaft, this is the only part in the carburetor that can be altered, Main jet is "Non Tech". Removal of material from the black plastic piece is allowed. No additional material may be added to any part of the carburetor, i.e. bolt in black plastic piece, tubing on throttle stop.
5. Rear mounting brackets for Honda fuel tank may be removed.

6. The starter cup that is behind the flywheel retaining nut can be cut away to leave only the flat washer back piece that retains cooling fan.
7. The keyed end of the ring gear shaft may be shortened, drilled and tapped or machined for snap ring.
8. Heli-coiling threads for shrouds (all), valve cover, existing throttle mounting holes, oil drain, and fill holes, one of the coil bolts, and side cover bolts is allowed. Dowel holes are not to be modified or relocated, also one carburetor mounting bolt.
9. Honing and deglazing of the bore is allowed.
10. Lapping the valves is allowed.
11. Blocking air flow: No device may be used that will/or appear that it may impede air flow into the engine cooling system. This may require that the engine be run at a speed above idle by the tech personnel at the scale after the car has qualified or raced.

CARBURETOR

HONDA 120 INSULATOR



HONDA GX120 CARBURETOR FOR JUNIOR & SENIOR HONDA

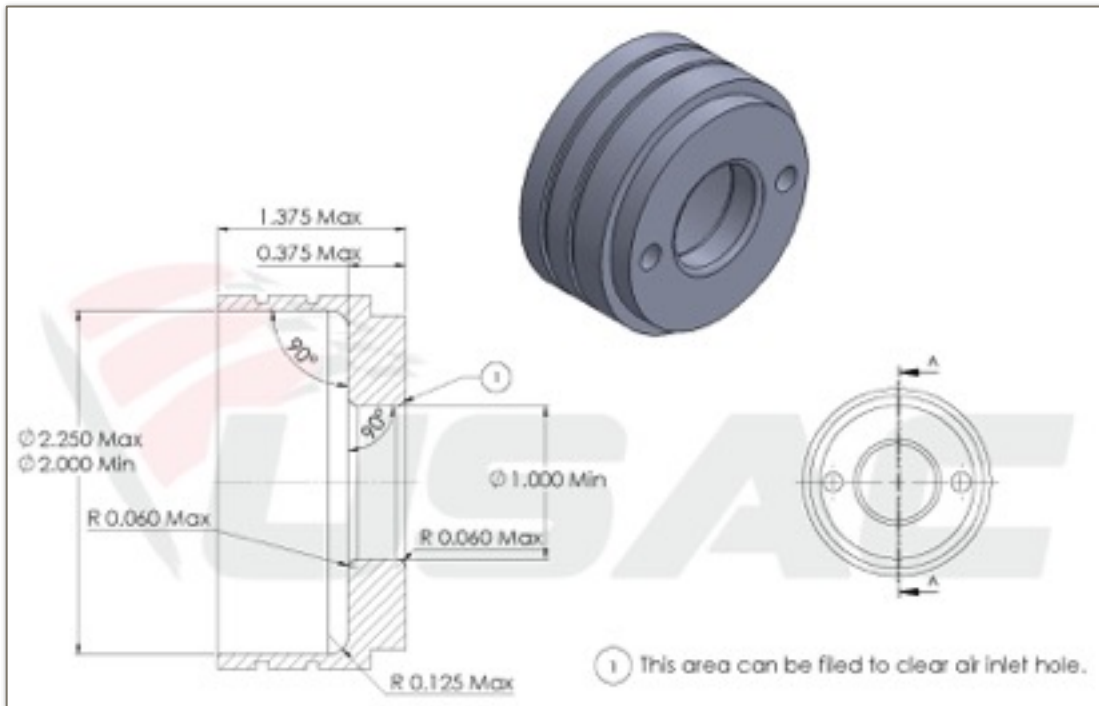

Remove Carburetor:

Air cleaner adapter:

- ID: 2.250" maximum
- Length: 1.375" maximum
- Flange thickness: 0.375" maximum
- Flange ID: 1.000" minimum

ID hole size straight walled, flat bottomed and parallel with carburetor using existing air cleaner mount holes. Carb adapters with machined spacers or bosses are legal for use. Carb adapters must meet the all the current dimensions with the following additions. Only 2 bosses may be added for the purpose of mounting to the carburetor. The maximum diameter of the bosses is 0.515 The maximum length of the bosses is 0.625. The top of the bosses must be machined flat. They may not be counter bored or have a radius. A maximum 0.010 radius can be added to break the top edge.

Restrictor Plates

- a. Red Rookie (Honda): - Red plate with single hole .3125" maximum
- b. Blue Rookie (Honda): - Blue plate with single hole .4375" maximum
- c. Jr Honda - Blue plate with single hole .4375" maximum - QMA plate legal only with a date of 06-09 or newer.

- d. The use of approved USAC plates is recommended. Red and Blue QMA plates are legal, dated 06/09 or newer.

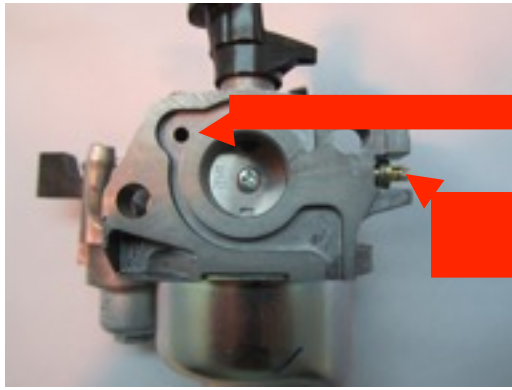

Float Bowl Vent.

Pilot Screw- Check tip and Pilot seat.



The **Pilot Air Jet** hole is just inside of this brass piece. This needs to be checked with the proper no-go gauge.

The hole at the end of the arrow is the **Main Air Jet** hole and will be checked using a pin type no-go gauge.



Once you remove the **Needle Valve** you can then check the **Needle Valve seat** dimension.



Remove the idle adjustment screw and then carefully pry up on the **Pilot Air Jet** to remove.

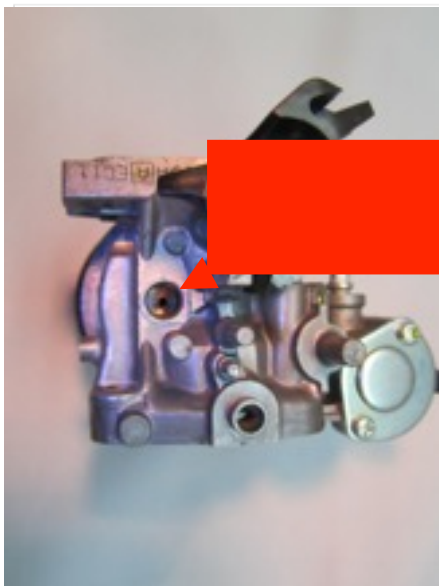

This is where the **Pilot Air Jet** is located. There is not a spec for this hole. The small hole in the bottom of the jet (black plastic) needs to be checked. Also look to make sure that the o-ring on the jet is there and in good condition.



GX 120 MAIN NOZZLE



GX 160 UT1 MAIN NOZZLE



GX 160 UT2 MAIN NOZZLE

1. Check for restrictor, if applicable, and placement. Restrictor must be installed between carburetor and carburetor insulator with stock Honda gasket on each side of restrictor. Only stock Honda insulator gasket between black plastic insulator and head is permitted. Gasket thickness: 0.025" maximum. Air passageway in insulator will not be altered in any way. All Junior Honda's must use the blue USAC approved slotted plate only or the blue QMA plate dated 06-09 or newer. Failure to use proper restrictor plate, alteration of restrictor plate, or improper installation of plate in designated class is cause for immediate DQ and all applicable suspensions will be applied.
 - a. Restrictor - Jr Honda - Blue Plate -Hole .4375" maximum
2. Restrictor thickness: 0.0625" maximum. No slotting of holes on any Honda restrictor.
3. Insulator gasket thickness: 0.025" maximum
4. Check for any alterations or worn parts that would allow additional air into engine: holes, slots, perforations, spacers, loose bolts, warped flanges, etc.
5. Two stock Honda intake gaskets may be used between Carburetor and plastic insulator.
6. Carburetor identification number:
 - a. Jr. Honda and Sr. Honda: BE60B, BE60R, UT2 carb BE99A
 - b. Heavy Honda: BE65B, BE65Q and BE54D -main nozzle 16166-ZH8-W50 may be used.
8. Check carburetor for alterations. Upper choke shaft hole may be sealed with silicone type sealer.
9. Honda 120 carb for Jr. and Sr. Honda
 - a. BE60B, BE60R, UT2 carb BE99A
 - b. Carburetor Bore: Intake end: Maximum diameter 0.951" Ref.
 - c. Throttle end: Maximum diameter 0.632".
 - d. Carburetor venture bore 0.456" no go. This measurement is best made with a no go gauge but may be measured using a telescoping gauge as a no go.
 - e. ~~Main jet in carburetor will be "Non Tech".~~ Must be a Honda OEM jet. (Brass or Silver Jet) Jet may be drilled to any size. No other modifications.
 - f. Main jet – Any size allowed. This specification refers to the main jet primary small center hole only. It is not legal for any other jet modifications and will be compared to a stock known factory jet. Counter boring and/or chamfering of the larger holes of the jet on both the front and back sides of jet are not allowed.
 - g. Main air jet: ~~0.0394" maximum~~ #60 (0.040") no go – at back of hole
 - h. Main jet access passage: ~~0.094" maximum~~ #41 (0.096") no go.

- i. Main nozzle bore ~~0.069" maximum #50~~ (0.070") no go.
- j. Main nozzle will be checked with a NOGO gauge (.429" maximum) If gauge goes over main nozzle-carb is illegal. This is best measured using a 0.452" rod type gauge with a 0.429" flat area to be used as a go gauge.
- k. Air vent holes on the side of the main nozzle must not be plugged.
- a. Main nozzle must not be fastened into the carburetor body by anything other than the main jet. It must not be epoxied or positioned by any other means.
- b. Pilot jet: ~~0.0138" maximum #79~~ (0.0145") no go
- c. Pilot air jet: ~~0.050" minimum~~ 1.25mm (0.0492") go.
- d. Pilot screw: no spec
- e. Pilot seat diameter: ~~0.035" maximum #61~~ (0.039") no go
- f. Tip of pilot screw: 0.019" minimum.
- g. Float bowl vent: ~~0.118" maximum #31~~ (0.120") no go.
- h. Needle valve seat: ~~0.065" maximum #51~~ (0.067") no go.
- i. The butterfly screw, the butterfly, and the throttle shaft must not be removed from the carburetor. Any evidence of tampering will be a disqualification and suspension.

Honda 160 carb for Heavy Honda

MUST USE Honda part number 16211-ZE0-000 Insulator for the Heavy Honda class. This is the standard GX-120 Insulator. No modifications allowed.

- a. BE65B, BE65Q and BE54D -main nozzle 16166-ZH8-W50 may be used
- b. Carburetor Bore: Intake end: Maximum diameter 0.951" ref.
- c. Throttle end: maximum diameter 0.710.
- d. Carburetor venturi bore; 0.523- no/go. This measurement is best made with a no go gauge but may be made using a telescoping gauge as a no go.
- e. Main jet is "non-tech" Must be an OEM Honda jet (Brass or Silver) Jets can be drilled to anysize.
- f. Main jet – Any size allowed. This specification refers to the main jet primary small center hole only. It is not legal for any other jet modifications and will be compared to a stock known factory jet. Counter boring and/or chamfering of the larger holes of the jet on both the front and back sides of jet are not allowed.
- g. Main air jet: ~~0.0587" maximum #53~~ (0.059") no go- at back of hole.

- h. Main jet access passage: ~~0.0942" maximum #41~~ (0.096") no go.
- i. Main nozzle bore: ~~0.0732" maximum #47~~ (0.078") no go.
- j. Main nozzle will be checked with a no/go gauge (0.424" maximum) if gauge goes over main nozzle – carb is illegal. This is best measured using a 0.519" rod type gauge with a 0.424" flat area to be used as a go gauge.
- k. Air vent holes on the side of the main nozzle must not be plugged.
- l. Main nozzle must not be fastened into the carburetor body by anything other than the main jet. It must not be epoxied or positioned by any other means.
- m. Pilot jet: ~~0.0135" maximum #79~~ (0.0145") no go.
- n. Pilot air jet: ~~0.0478" maximum #55~~ (0.052") no go
- o. Pilot screw: no spec
- p. Pilot seat diameter: ~~0.0365" maximum #61~~ (0.039") no go.
- q. Tip of pilot screw: 0.020" minimum
- r. Float bowl Vent: ~~0.118" maximum #31~~ (0.1200") no go.
- s. Needle valve seat: ~~0.0685" maximum #31~~ (0.1200") no go.
- t. The butterfly screw, the butterfly, and the throttle shaft must not be removed from the carburetor. Any evidence of tampering will be a disqualification and suspension.

ENGINE COOLING SHROUDS

1. All pieces of the stock engine cooling shroud must be properly installed.
2. There must be no addition or subtraction of any material from the shrouding except for the covering of the switch hole (any material). Starter cup may be altered to be used as washer retainer for the cooling fan.
3. Remove engine cooling shrouds. Remove valve cover.
4. Zero dial indicator after exhaust bump. (0.050) ref.
5. Maximum valve lift will be checked from the top of valve spring retainer. Valves may be adjusted to zero clearance or shims may be installed to create zero clearance. This may dictate making special shims, as it is difficult to insert feeler gauge blades so as not to interfere with indicator contacts on retainer.

Valve lift:	Intake:	0.245" maximum
	Exhaust:	0.255" maximum

CYLINDER HEAD, HEAD GASKET, VALVES, SPRINGS.

1. Remove cylinder head.
2. Head gasket thickness:
0.040" minimum thickness of inner rim.
3. Thickness of the head will be measured from valve cover surface to head gasket surface on the side, at a position in line with the upper intake and exhaust flange bolt.
-Minimum 2.911. Japan "RK" series heads, Min thickness 2.911". Thailand HPD "TKI9" only, head Min thickness 2.900".



Japan "RK" Cylinder head measurements

- A) Measure from head deck surface to valve cover surface, 2.911" Min.
- B) Measure from head deck surface down to the top of the valve.
Intake & Exhaust 0.178" Min 0.265" Max
- C) Measure from head deck surface down to the top of the valve seat.
Intake & Exhaust 0.250" Min 0.265" Max
- D) Measure from head deck surface to the top of the valve guide.
Intake 0.925" Max Exhaust 0.925" Max
- E) Measure from head deck surface down to the lowest machined area of the bowl.
Intake 1.064" Max Exhaust 1.010" Max
- F) Intake & Exhaust port dia. at the valve
Intake 0.745" Min Intake 0.753" Max
Exhaust 0.665" Min Exhaust 0.675" Max

Thailand HPD TKI 9 series cylinder head P/N 12210-ZH7-0207 & P/N 12200F23SB000 are the ONLY approved Thailand cylinder heads for use on the Honda GX-120 engines for USAC competition as of April 15, 2016. These heads must have the Honda Racing HPD logo. This head will be available in 2 different configurations. One is with stock intake port and the second is with a modified intake port. The use of any other TKI numbered Thailand head is not permitted and will result in a race day "DQ". Illegal head will be removed from service excluding all components of the head.

HPD TKI 9 STOCK INTAKE PORT P/N 12210-ZH7-0207
Thailand HPD TKI 9 Cylinder head measurements

- A) Measure from the head deck surface to valve cover surface.
2.900" MIN
- B) Measure from head deck surface down to the top of the valve.
Intake & Exhaust 0.168" Min 0.210" Max
- C) Measure from head deck surface down to the top of the valve seat
Intake & Exhaust 0.250" Min 0.265" Max
- D) Measure from head deck surface to the top of the valve guide
Intake & Exhaust 0.925" Max
- E) Measure from head deck surface down to the lowest machined area of the bowl.
Intake 1.042" Max Exhaust 0.968" Max
- F) Intake and Exhaust port diameter at the valve
Intake 0.745" Min 0.753" Max
Exhaust 0.665" Min 0.675" Max

Cylinder heads that have had the thickness cut below 2.907", all measurements will need to conform to the modified head dimensions.

HPD TKI 9 WITH MODIFIED INTAKE PORT P/N 12200F23SB000
Thailand HPD TKI 9 cylinder head measurements

- A) Measure from the head deck surface to valve cover surface.
2.900" MIN
- B) Measure from head deck surface down to the top of the valve.
Intake & Exhaust 0.168" Min 0.210" Max
- C) Measure from head deck surface down to the top of the valve seat
Intake & Exhaust 0.235" Min 0.250" Max
- D) Measure from head deck surface to the top of the valve guide
Intake and Exhaust 0.925" Max
- E) Measure from head deck surface down to the lowest machined area of the bowl.
Intake 1.064" Max Exhaust 0.955" Max
- F) Intake and Exhaust port diameter at the valve
Intake 0.745" Min 0.753" Max
Exhaust 0.665" Min 0.675" Max

****IT IS RECOMMENDED THAT WHEN MEASURING THE DEPTH OF THE INTAKE & EXHAUST BOWL, THAT IT IS DONE AS CLOSE TO THE VALVE GUIDE AS POSSIBLE. ON THE INTAKE BOWL, MEASURE ON THE SIDE THAT THE INTAKE RUNNER ENTERS THE BOWL. ON THE EXHAUST SIDE, MEASURE THE SIDE THAT THE EXHAUST RUNNER EXITS THE BOWL.**

- 4. Remove valves:
- 5. Inspect retainers for alteration that would increase valve spring pressure. Both intake and exhaust must have stock Honda retainers. Exhaust valve only can have lash cap and corresponding retainer.
- 6. All valve oil seals must be removed.
- 7. The use of valve seals is illegal and will result in applicable suspension per Honda

suspension program.



UT1 - Retainer

Thickness of retainer will be:

Intake: 0.228" minimum

Exhaust 0.241" minimum

Flange thickness of retainer will be:

Intake: 0.110" maximum

Exhaust: 0.070" maximum

From flat of flange to machined surface:

Intake: 0.148" minimum

Exhaust: 0.165" minimum

UT2 - Retainer

Thickness of retainer will be:

Intake: 0.228" minimum

Exhaust 0.228" minimum

Flange thickness of retainer will be:

Intake: 0.110" maximum

Exhaust: 0.110" maximum

From flat of flange to machined surface:

Intake: 0.148" minimum

Exhaust: 0.148" minimum

VALVE SPRINGS

1. Valve springs will be stock Honda springs and will not be altered in any way. Use of Honda GX120 or 140 valve springs legal
2. 120 springs
 - a. Wire diameter: 0.071" maximum
 - b. Outside diameter of spring: 0.790" maximum
 - c. Number of total coils: 5.3
 - d. Spring pressure: 11 lbs maximum at 0.812"
 - e. Stacked length will be: 0.394" maximum



- 3. 140 Springs
 - a. Wire Diameter: 0.079" maximum
 - b. Outside diameter of springs : 0.816" maximum
 - c. Total number of coils: 7
 - d. Spring pressure: 16 lbs. maximum at 0.812"
 - e. Stacked length: 0.524" maximum

ROCKER ARMS – PUSH RODS- STUDS

- 1. Rocker arms will be stock Honda and will not be altered in any way.
- 2. Rocker arm studs will be stock Honda. They or their mounting position may not be altered in any manner. No heli-coiling of mounting holes. No bending of studs.
- 3. Push rods will be stock Honda and will not be altered in any way.
Push rod length: 4.803" max.

VALVES



INTAKE VALVE



UT1 -EXHAUSTVALVE

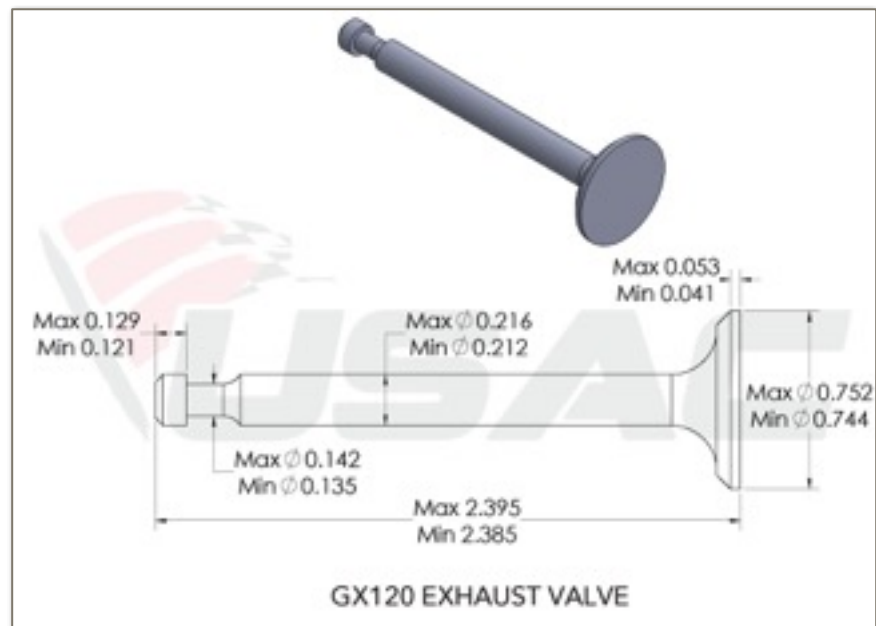
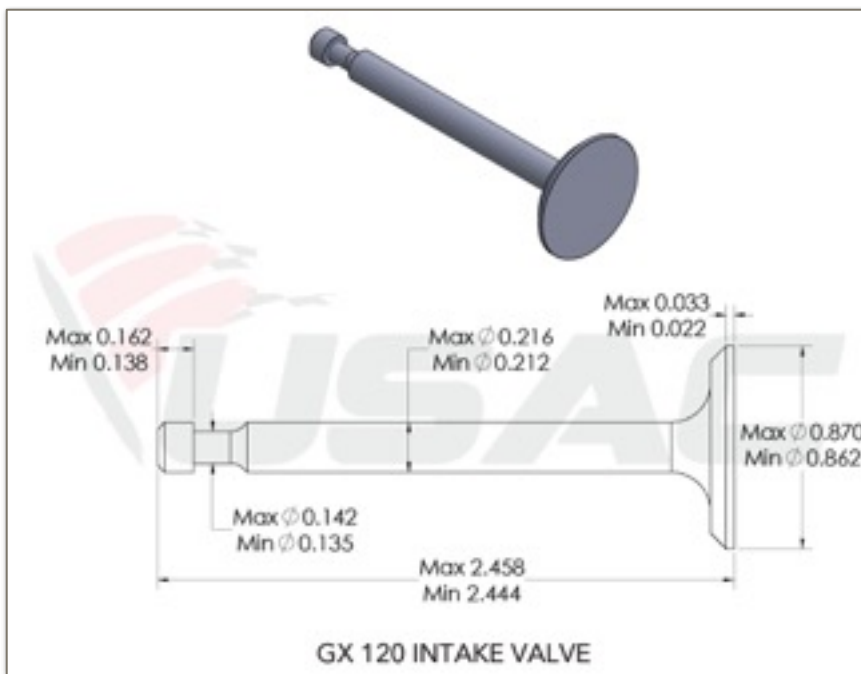

1. Check valves for dimensions and weight.
2. Valve seating surface must be factory ground to a single angle only, 45 degrees. There will be no other angles ground on any part of valve. Valves must not be polished, lightened or altered in any way.

3. Valve weight:
 - Intake 18 grams minimum
 - Exhaust 16 grams minimum

There are two different exhaust valve combinations available to use. You can not mix and match parts from the two combinations.

If you choose to run the UT-1 exhaust valve part #14721-ZF0-000 you must use Retainer #14773-ZE1-000 and Lash Cap #14781-ZE1-000.

If you choose to run the UT-2 exhaust valve part #14721-Z4H-000 you must run retainer #14771-ZE1-000. You can not run a Lash Cap with this combination. The UT2 exhaust valve part #14721-Z4H-000 measures ~2.470 overall length.

HEAD

1. Cylinder head will be in “as cast” and in factory machined condition. There may be no addition or subtraction of metal except for cylinder head gasket surface.
2. No use of any substance to the inside of the cylinder head. This includes no type of machining or grinding to increase airflow. No angle milling, etc. or any alteration that could increase valve spring pressure.
3. Japan UT1, RK heads are legal, some of the original UT1 heads had grinding and filing marks located in the ports. Heads with grinding or filing will not be legal. It is your responsibility to make sure your engine’s head hasn’t been ground or filed. **Thailand UT2, HPD TKI 9 series cylinder head Part # 12210-ZH7-0207 & Part # 12200F23SB000 are the “Only” approved Thailand cylinder head for use on the Honda GX-120 engines for USAC competition as of April 15, 2016.** These heads must have the Honda Racing HPD logo. This head is available in 2 different configurations. One is with stock intake port and the 2nd is with a modified intake port. The use of any other TKI numbered Thailand head is not permitted and will result in a Race Day DQ and loss of points for that event. Illegal head will be removed from service excluding all components of the head.
4. Cleaning of the combustion chamber or changing the finish of such chamber is illegal.

INTAKE AND EXHAUST PORTS

1. Ports will be in “as cast” and factory machined condition and there must be no addition or subtraction of metal or any other substance to the inside or outside of the cylinder head.
2. No alterations of any kind to be made to the intake or exhaust port. This includes any grinding, polishing, etching, sand blasting or glass beading to interior surface.
3. Valve seats must be a stock single 45 degree angle. Multi angle valve seats are not permitted. Valve seats must not be replaced.
4. Intake and Exhaust ports at valve:

Intake:	Maximum 0.752”
	Minimum 0.745”
Exhaust:	Maximum 0.675”
	Minimum 0.665”

ENGINE BLOCK



**Must be an OEM Honda Cylinder block. No aftermarket blocks.
Honda Performance Development has Honda replacement blocks available.**

1. This engine block must be in “as cast” and factory machined condition. There must be no addition or subtraction of metal or any other substance to the inside or outside of the cylinder block, crankcase cover, crankshaft, rod, piston, pin, rings, flywheel or coil with the following exceptions:
 - a. Removal of rear gas tanks brackets is permitted.
 - b. Removal of governor. Governor system may be partially removed with the exception of the steel gear on the crankshaft. This gear must remain intact. Governor arm and shaft may be removed, tied forward or altered to accommodate throttle linkage or return springs.
2. Addition of brackets, fittings etc. to accommodate throttle linkage, tachometer and temperature gauge is allowed.
3. Cylinder head gasket surface may be milled ~~., but must be flat. No angle milling allowed.~~
4. Check bore:
2.366” maximum.

NOTE: All measurements taken from the top to bottom of the bore, preferred method of measurement is dial bore gauge, dial calipers may be used. Take out of service with no DQ or suspension.

“Wear Limits/Parts Out of Service” USAC reserves the right to confiscate 120 Honda engine parts deemed illegal or at USAC maximum wear limits. EXAMPLE: cylinder bore will be 2.366 maximum all measurements taken from the top to the bottom of the bore parallel to crank, 90 degrees from crank. Any cylinder block that has one measurement over USAC maximum wear limits will be taken out of service. If no measurements exceed USAC maximum wear limits the part of the block will not be confiscated. Handler has the right to have confiscated parts returned to them but will be rendered unusable.

5. Check stroke:
1.659” Maximum
1.640” Minimum
6. Measure amount that piston is up or down from block surface at T.D.C. This will be measured at the edge of piston top and bottom and side to side. When measuring top and bottom of piston take an average of the numbers measured i.e. top = .003, bottom = -.003 the piston to deck would be .000. Measurement must NOT be taken in

the center or relieved part of the piston. This dimension will be: 0.000" Max – NO PISTON POP UP!!! Carbon may be removed to check pop-up.

7. Install degree wheel on flywheel. Install pointer in order to read degrees. Locate accurate T.D.C. this should be done with a positive stop type fixture and not established with indicator alone.
8. Cam can be checked with indicator reading off the top end of tappets or end of top end of pushrod which will provide zero clearance. The inverted radius of the top of the tappet presents some problem to get accurate readings and to prevent binding of indicator stem. Indicator holder and positions are very critical in this operation.
9. Zero indicator on base circle of cam. Be sure that compression does not affect zeroing exhaust indicator. (zero dial indicator after exhaust bump) ref.
10. Turning engine in normal rotation, clockwise facing flywheel, take reading at specified opening. Readings must fall between specified degrees on the following chart.
11. Check max lift at intake and exhaust.

CAMSHAFT PROFILE INFORMATION							
INTAKE DEGREES				EXHAUST DEGREES			
0.050"	10.5 – 14	ATD		0.050"	206.5 – 210.5	BTD	
0.100"	26.5 – 30	ATD		0.100"	189.5 – 193.5	BTD	
0.150"	45 - 49	ATD		0.150"	170.5 – 174.5	BTD	
0.200"	71 - 76	ATD		0.200"	144 - 148	BTD	
MAX LIFT	0.227"			MAX LIFT	0.229"		
0.200"	135 - 141	ATD		0.200"	70.5 – 74.5	BTD	
0.150"	162 - 167	ATD		0.150"	44.5 – 48.5	BTD	
0.100"	180 - 185	ATD		0.100"	26 – 29.5	BTD	
0.050"	197 - 201	ATD		0.050"	9 – 12.5	BTD	

FLYWHEEL, FAN AND IGNITION SYSTEM



Caution should be used when removing flywheel. Do not hit with hammer or other heavy objects. Service manual show flywheel to be removed with commercially available 6" puller. Another method is inertia type knocker that threads onto crankshaft end.

1. The transistorized magneto ignition is fixed at 20 degrees BTDC and may not be altered in anyway.
 - a. Firing must not exceed .065" or 20 degrees BTDC.
Quick check: Turning flywheel clockwise if the leading edge of depression of flywheel rim where the magnet is mounted is not still under the right hand coil leg at .065" BTDC, it is probably illegal and should be checked further.

PROCEDURE FOR CHECKING TIMING

1. Ignition timing is to be checked with a degree wheel and a fixed pointer mounted on the engine. Use a piston stop tool inserted in the spark plug hole to properly locate the piston top dead center (TDC) position. Using a hand held electric drill, rotate the engine in a clockwise direction and with a timing light check the ignition timing.

Honda 120

Rotation speed between 1200 - 2000 RPM

Max. timing = 20 degrees

Flywheel key = Offset and or modified key is allowed.
Coil leg to flywheel gap = .035 Max.

2. Tier II Flywheel is no longer legal. You may use any key on Tier III Flywheel to reach maximum timing of 20 degrees.
3. Magnet and/or its position may not be altered in any way. Tier III magnet black.
4. Magnet retaining screw may not be altered in any way. Screw may not be replaced with larger or smaller screw. No heli-coiling of mounting hole.
5. Ignition coil and/or its position, may not be altered in any way. The air gap on the coil is a tech item with a max gap dimension, see (d) below.
 - a. Coil mounting bolts must be stock and cannot be altered in any way to advance or retard timing. Coil attaching bolts will be stock 6mm cap screw 1-1/16" long.
 - b. There can be no more than 3/8" of unthreaded portion of bolt that does not measure 0.230" diameter. This restricts movement of coil to a position that could make ignition timing illegal.
 - c. If a coil support mount becomes stripped, it is permissible to heli-coil. However, only one leg may be repaired, if both legs are heli-coiled, the block becomes illegal.
 - d. Max air gap 0.035" - this can be accomplished with a set of feeler gauges. The gauge can't pass under the full length of each leg of the coil and the flywheel OD.
6. All nylon blades on the cooling fan must be intact. Race day DQ for any missing blades.
7. No metal removal or addition to flywheel is permitted.
8. Flywheel weight will be:
1550 grams minimum
9. Flywheel diameter – magnet area:
6.285" minimum
10. A stock Honda spark plug cap, (wire end at resistor), must be used.
11. Any unaltered automotive type spark plug & unaltered spark plug washer may be used.
12. No plug indexing washers allowed.
13. If temperature sensor is used under spark plug, factory washer may be removed.



**GX-120 FAN
GEAR BOX AND RING GEAR**



1. Gear box may not be altered in any way.
 - a. May be rotated to desired position.
2. Ring gear may not be altered in any way with the exception of the keyed end of shaft that may be shortened, drilled and tapped or machined for snap ring groove. No other machining, drilling, grinding etc. to ring gear.
 - a. Key way may be cut deeper.
3. Ring gear may not be altered in any way including polishing or use of any compound or abrasive on gear shaft where bearing rides.
4. Two gaskets maximum between gear box halves.

CRANKCASE COVER

1. Remove crankcase cover.
2. Cover must be in "as cast" and factory machined condition and there must be no addition or subtraction of metal or any other substance to crankcase cover.

3. Crankcase cover gasket must be stock Honda. Only one gasket may be installed with a maximum thickness of 0.025".
4. Critical dimensions are thrust face of camshaft holder and position of crank bearing.
 - a. Place a straight edge over crank bearing and cam boss thrust face. These surfaces should be level.
 - b. Maximum tolerance will be 0.005". There will be no alterations to crankcase cover. This includes any alteration to crank bearing and camshaft holder position and height in an attempt to alter valve timing.

PISTON, WRIST PIN, AND PISTON RINGS

1. Remove rod and piston – triangle or boss on top of piston must point toward push rods
2. Piston, wrist pin and rings must be absolutely stock and not altered in any manner.

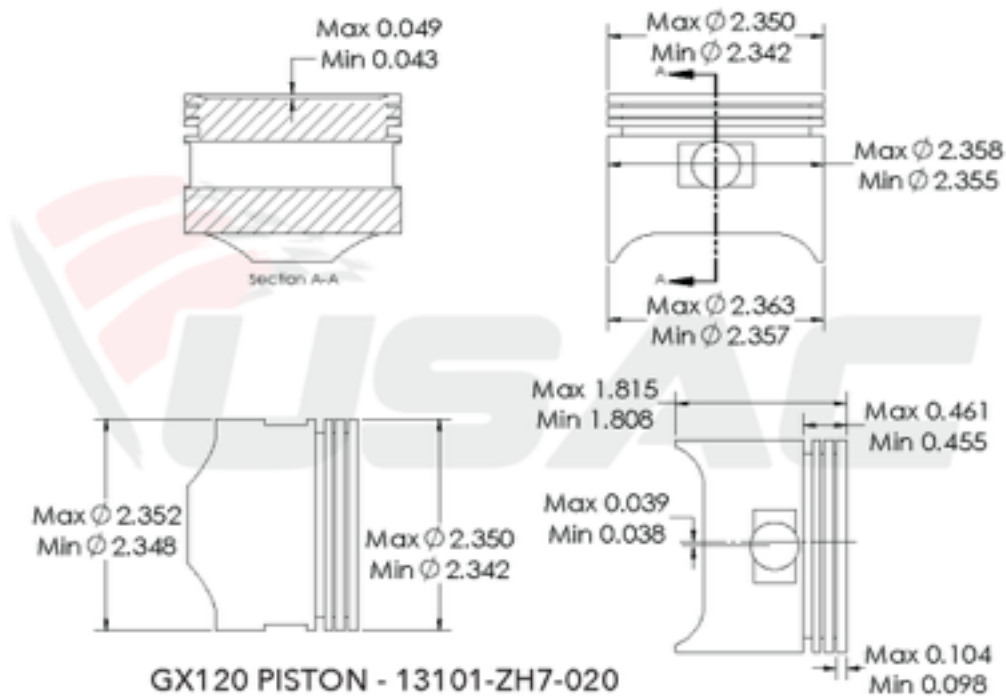



TIER III PISTON



TIER II PISTON

PISTON

1. Piston will be stock Honda standard size and will not be altered in any way.
2. Oversized pistons must not be used.
3. All three piston rings must be used
 - a. Top ring: Chrome compression ring installed with “N” or “T” on a rail up. No expander under ring.
 - b. Middle ring: Oil scraper ring installed with “N” or “T” on rail up. No expander under ring.
 - c. Bottom ring: Three (3) piece oil rings are allowed.
4. Piston may not be knurled, grooved or coated.
- 5.
6. Piston weight:
 - 106 grams minimum.
6. Total Piston weight with rings, pin, and clips:
 - 121 grams minimum.
7. Total Piston weight with rings, pin, clips, complete with rod and bolts:
 - 263 grams minimum.
8. See drawing for dimensions.

RINGS

1. Must be stock Honda rings with stock size and configuration.
2. No decreasing of ring tension by heating, machining or any other means.
3. Tier II Piston Ring Thickness:
 - a. Compression: 0.056” min.
 - b. Scraper: 0.056” min.

- c. Oil ring: 3 piece lower 0.095" min.
 - i. 1 piece 0.097" min.
- 4. TIER III Ring Thickness:
 - a. Compression: 0.036" min.
 - b. Scraper: 0.036" min.
 - c. Oil expander ring total length = 7.160 minimum.
 - d. Oil Ring: 3 piece lower 0.095" min.
 - i. 1 piece 0.097" min.
- 5. The letter "N" or "T" on Tier III piston rings may not be legible after engine has been run.

WRIST PIN

- 1. Stock Honda wrist pin and retainer
 - a. OD: 0.511 ref.
 - b. Length: Minimum 1.844"
Maximum 1.864"
 - c. ID: 0.354" ref.
 - d. Weight: 23 grams minimum

CONNECTING ROD



- 1. Stock Honda rod with no alterations.
- 2. Connecting rod big end size:
 - 1.021" minimum
 - 1.0265" maximum

3. Pin end bore is 0.5111 ref.
4. Length from bottom of pin bore to top of big end bore will be:
2.111" maximum
2.101" minimum
5. Rod weight with bolts: 119 grams or 4.2 oz minimum
6. No oil grooves on bearing surface of either end.

CRANKSHAFT



THAILAND CRANKSHAFT

JAPAN CRANKSHAFT

1. Stock Honda crankshaft with no alterations.
2. No removal or addition of any metal from or to the crankshaft is allowed.
3. No balancing of the crank is allowed
4. No oil grooving is allowed on the crank journal
5. Governor drive gear ca not be removed.
6. Crankshaft drive gear should not be removed. This gear is installed by Honda to any accuracy of + 1/2 degree. If this gear is not installed to this degree of accuracy; engine may not be legal when camshaft is checked by the procedure under engine block.
7. Keyway location must not be altered in any manner.
8. Measure thrust to crank gear side: 3.340 Min.
9. The only cleaning method allowed is on the flywheel side of crankshaft for the purpose of removing calcium, rust etc. from the exposed end of the crankshaft. This is permitted only from the seal groove out to the end of the thread of the crankshaft where the flywheel bolts on. Only a wire wheel may be used in the cleaning process. The use of Scotchbrite, sandpaper or any other compounds or abrasives is illegal. No material may be added or removed from crankshaft.
10. Crankshaft main journal at flywheel and gearbox ends may not be altered in any way.

CAMSHAFT

1. Camshaft must be stock Honda with no alteration of any kind.
2. There will be no additions to or subtractions from any part of the camshaft.



3. Compression release will remain intact and unaltered.
4. Lobe center angle will not be altered by any means.
5. Lobe profile will not be altered in any way.
6. Camshaft specifications

INTAKE	EXHAUST
Heel to heel 0.864" – 0.869"	Heel to heel 0.865" – 0.870"
Heel to Peak 1.079" – 1.093"	Heel to peak 1.081 – 1.095"

Length – thrust flange to thrust flange:
3.135" minimum
3.142" maximum
7. Cam bearings are 0.547" – 0.551" and unaltered. (under 0.547" minimum will be taken out of service with no DQ.)

TAPPETS

1. Tappets must be stock Honda with no alterations.
2. Basediameter:
0.909" minimum
3. Stem diameter:
0.312" minimum

4. Base thickness:
 - 0.076" minimum
 - 0.090" maximum
5. Length:
 - 1.181" minimum
 - 1.220" maximum
6. Weight:
 - 16 grams minimum

ENGINE BLOCK INTERNAL

1. The engine block must be in an "as cast" and factory machined condition and there must be no addition or subtraction of metal or any other substance to the inside or outside of the block except for cylinder head gasket surface may be milled to achieve a 0.00 piston pop up. No angle milling of the cylinder surface. Must remain flat.
2. Cylinder bore will be 2.366" maximum. NOTE: all measurements taken at top of bore or very bottom of bore.

"Wear Limits/Parts Out of Service" USAC reserves the right to confiscate 120 Honda engine parts deemed illegal or at USAC maximum wear limits. EXAMPLE: Cylinder bore will be 2.366 Max. all measurements taken at top of bore or very bottom of bore parallel to crank, 90 degrees from crank. Any cylinder block that has one measurement over USAC maximum wear limits will be taken out of service. If no measurements exceed USAC maximum wear limits the part of block will not be confiscated. Handler has the right to have confiscated parts returned to them but will be rendered unusable.

3. Cylinder bore will not be bored oversize.
4. Cylinder bore will not be re-sleeved.
5. Cylinder bore position will not be moved or tipped in any manner.
6. There will be no polishing, sandblasting or glass beading to any interior surface.
7. Machined surface of block down to thrust face of cam boss:
 - 3.228" minimum
 - 3.240" maximum
8. Machined surface of block down to bearing face:
 - 3.430" minimum
 - 3.442" maximum
9. Oil level sensor will be intact and unaltered. Wires may be externally disconnected or cut off.



Tech officials have the right to tech any or all cars in any class at their discretion.

Parts in question that need further review, must be sealed and boxed up at the track in front of the handler. The handler and tech director must also sign a slip indicating that they both acknowledge the part is in question. The part must then be shipped to the USAC National office at 4910 West 16th Street, Speedway, IN, 46224.

No.	Size of Drill
1	.228
2	.
3	.
4	.
5	.
6	.204
7	.
8	.
9	.
10	.
11	.181
12	.
13	.
14	.
15	.
16	.177
17	.
18	.
19	.
20	.

No.	Size of Drill
21	.1590
22	.1570
23	.1540
24	.1520
25	.1495
26	.1470
27	.1440
28	.1405
29	.1360
30	.1285
31	.1200
32	.1160
33	.1130

34	.1110
35	.1100
36	.1065
37	.1040
38	.1015
39	.0995
40	.0980

No.	Size of Drill
41	.0960
42	.0935
43	.0890
44	.0860
45	.0820
46	.0810
47	.0785
48	.0760
49	.0730
50	.0700
51	.0670
52	.0635
53	.0595
54	.0550
55	.0520
56	.0465
57	.0430
58	.0420
59	.0410
60	.0400

No.	Size of Drill
61	.030
62	.
63	.
64	.
65	.
66	.022
67	.
68	.
69	.
70	.

71	.333
72	.
73	.
74	.
75	.
76	.333
77	.
78	.
79	.
80	.

Decimal Equivalents of Number Size Drills